

D2 Waterproof connector



Applications:

- E-Bike
- E-Scooter
- Drone
- Vacuum Cleaner
- Energy storage battery
- electric lawn mower
- AGV



Male Connector

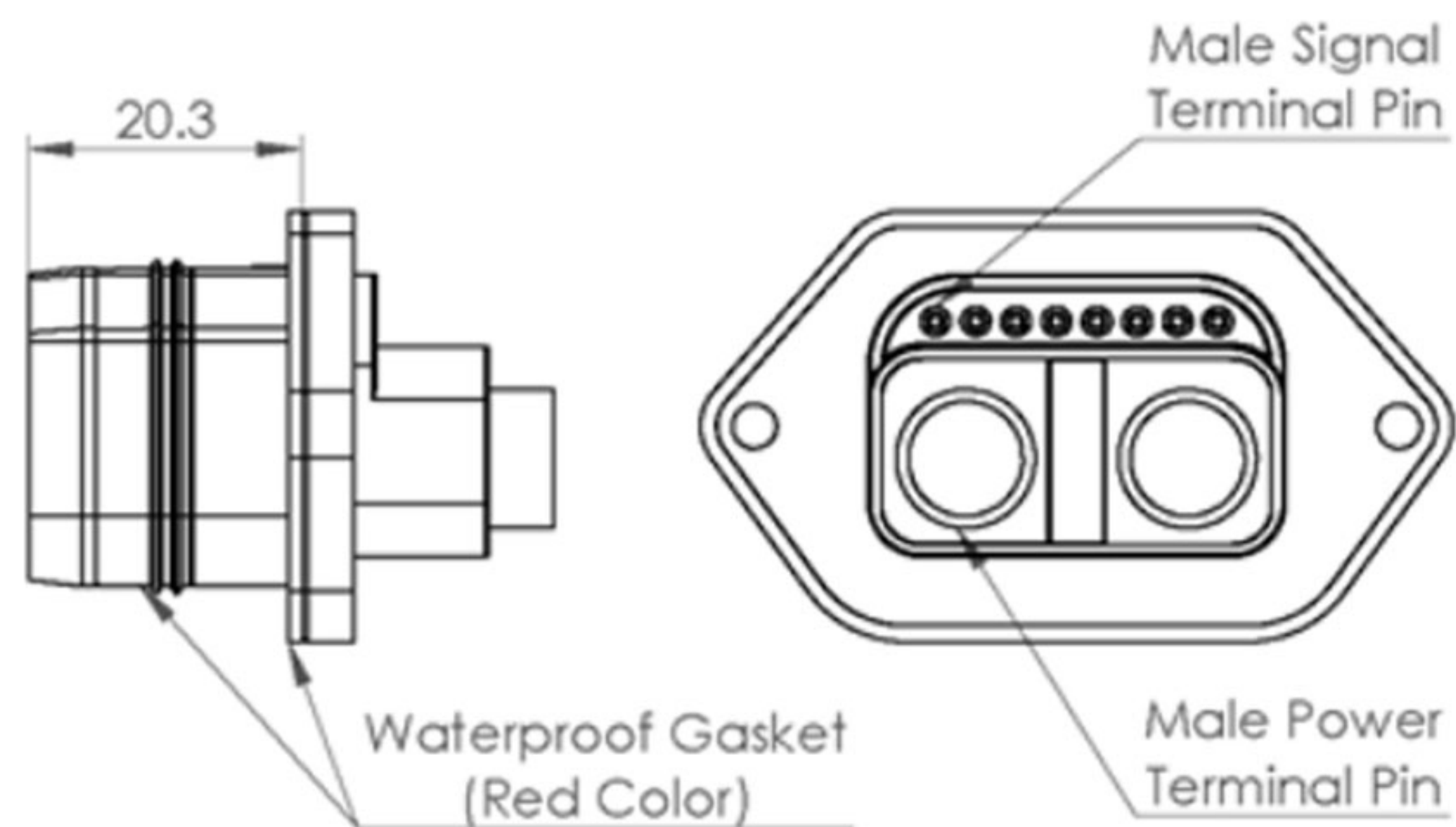
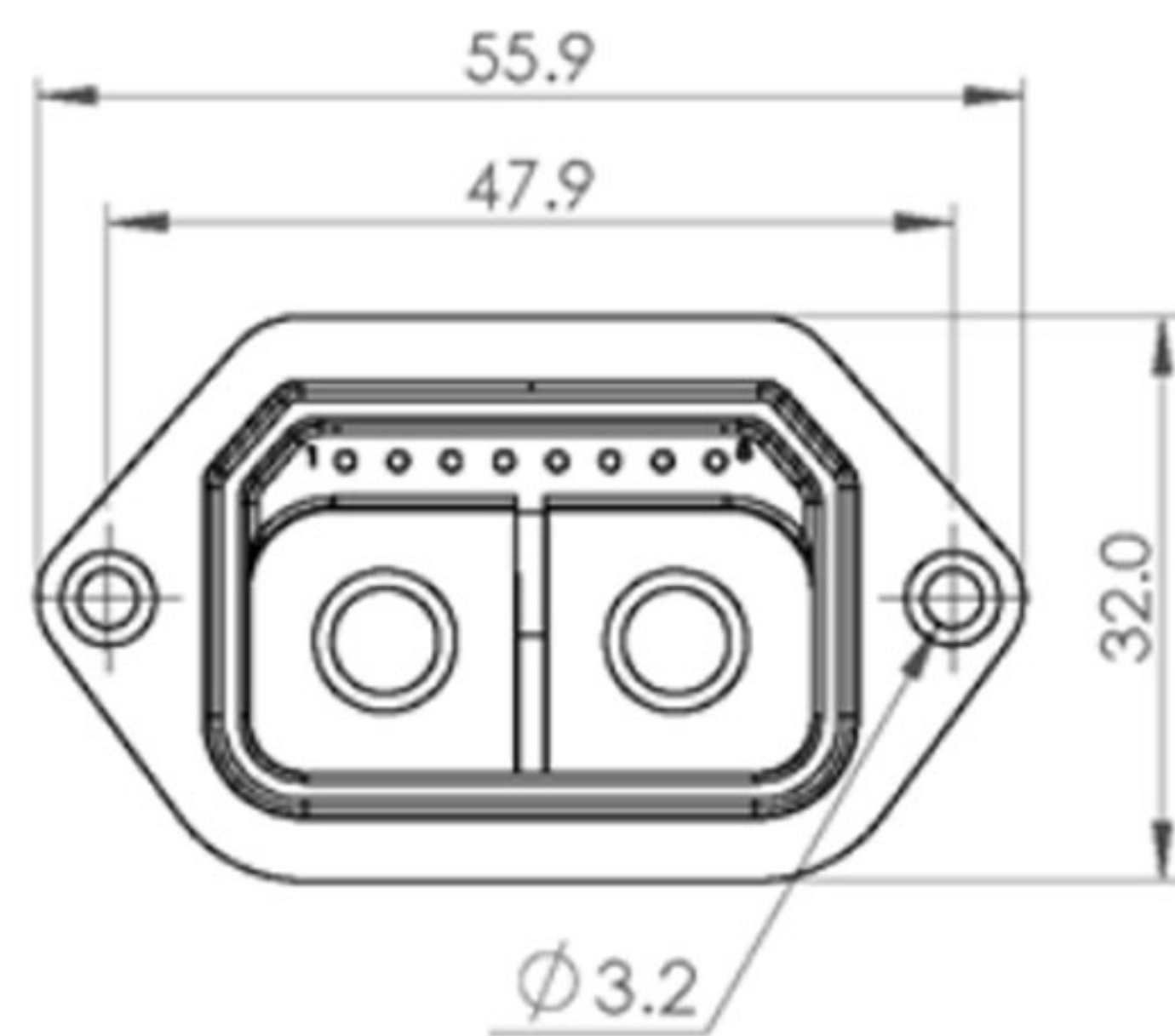

Female Connector

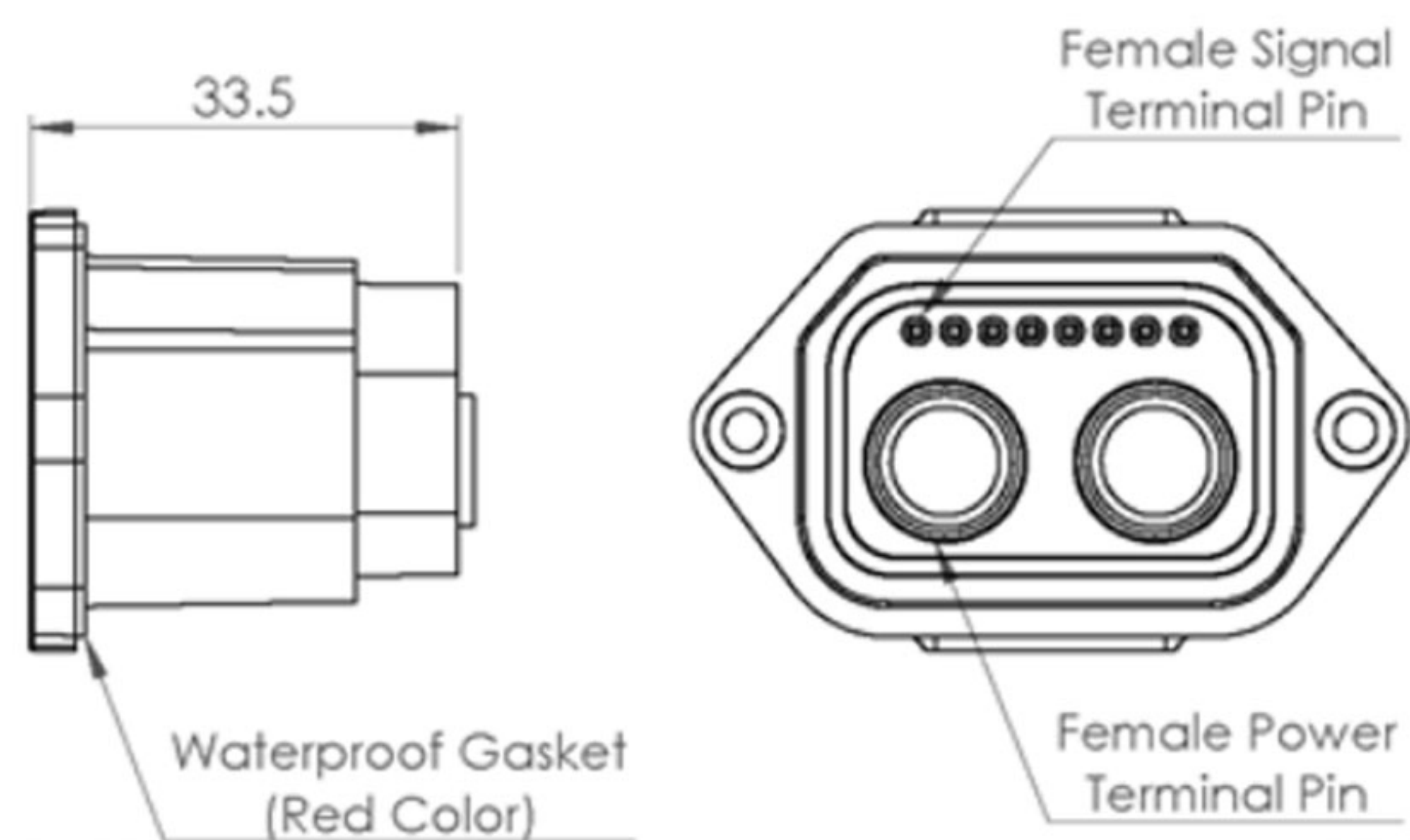
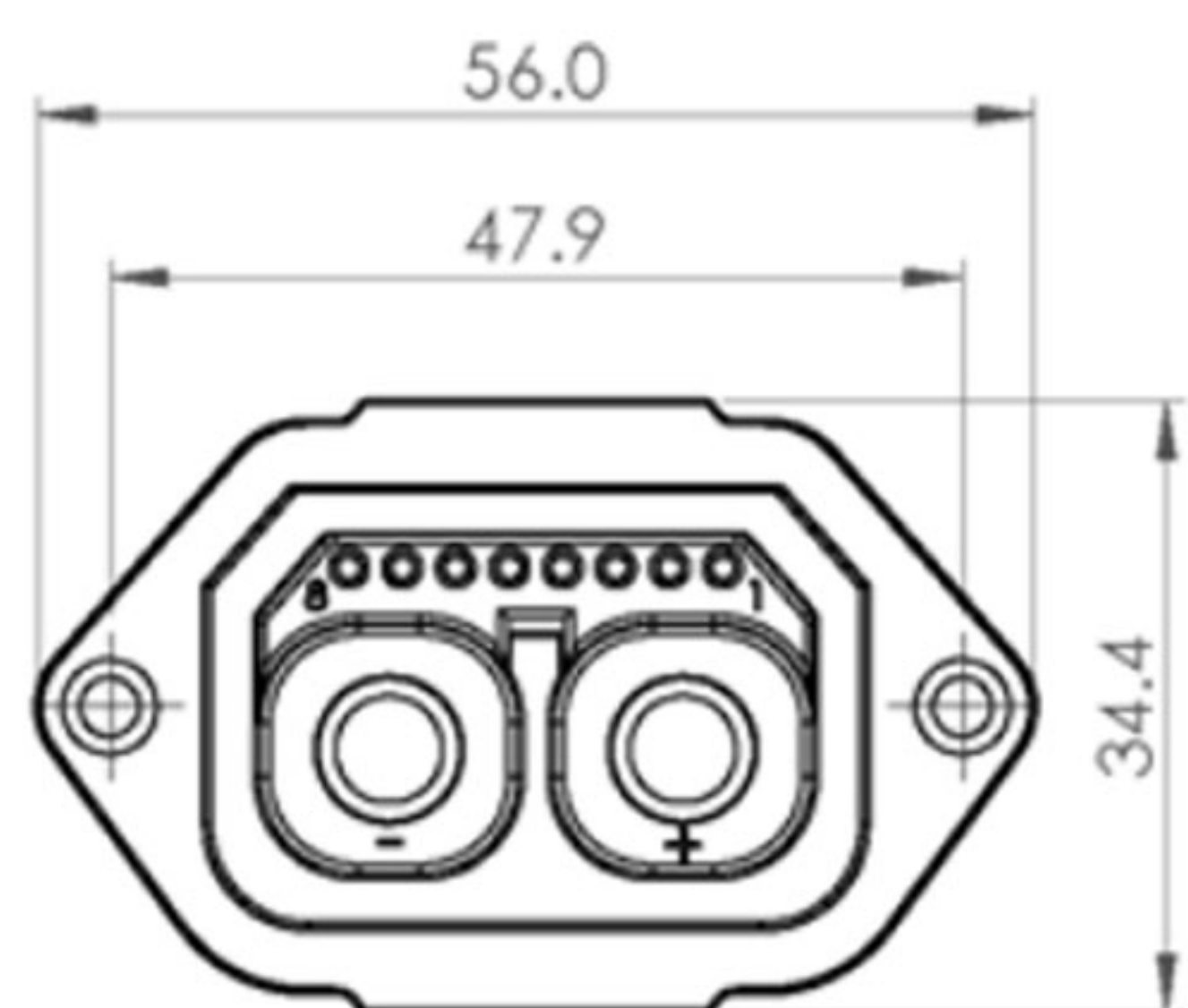

D2 Waterproof connector

Features

Terminal	2 PWR. pin & 8 SIG. pin
	100A(4AWG)120A(2AWG)
Current withstand	(Instantaneous peak current 130A)
	SIG.Terminal 2A
IP rating	IP68
Material of housing	PA66+15%GF UL94 V0

Wire Information

Wire Spec. for Standard Sample	
Wire Gauge	
Power Terminal	4AWG to 2AWG
Signal Terminal	26AWG to 24AWG