

C2 Waterproof connector



Applications:

- E-Bike
- E-Scooter
- Drone
- Vacuum Cleaner
- Energy storage battery
- electric lawn mower
- AGV



Male Connector

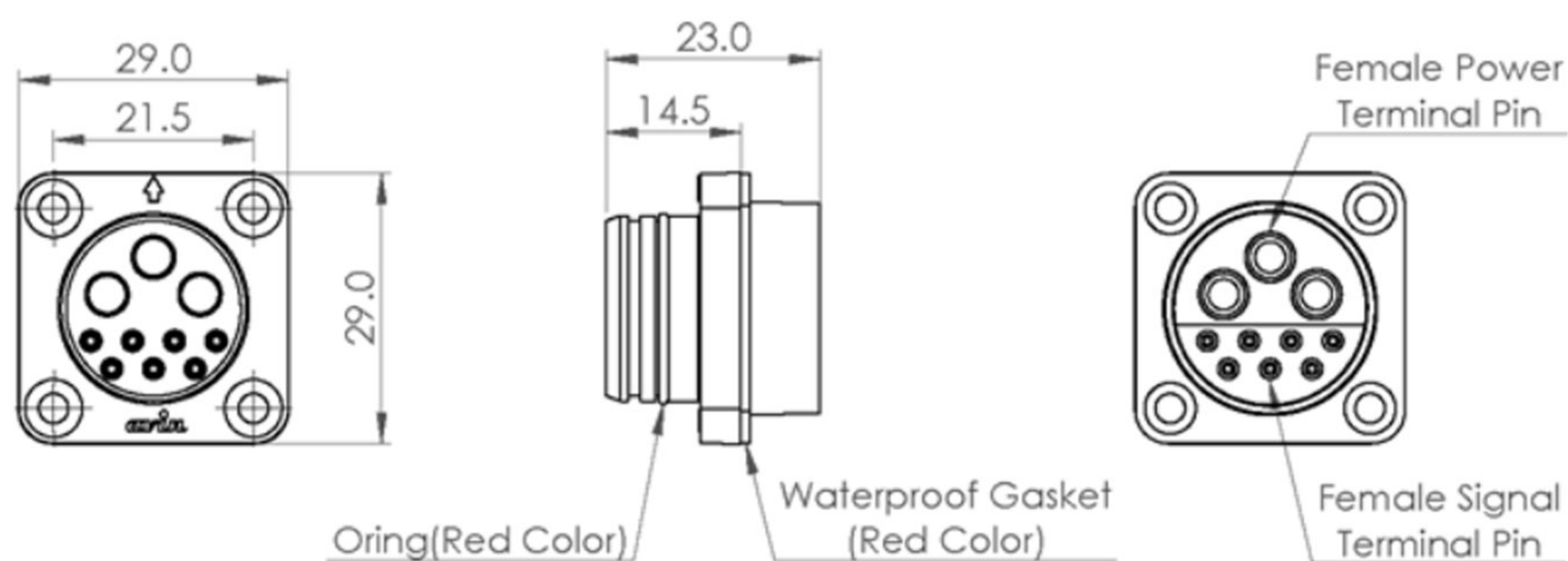

Female Connector

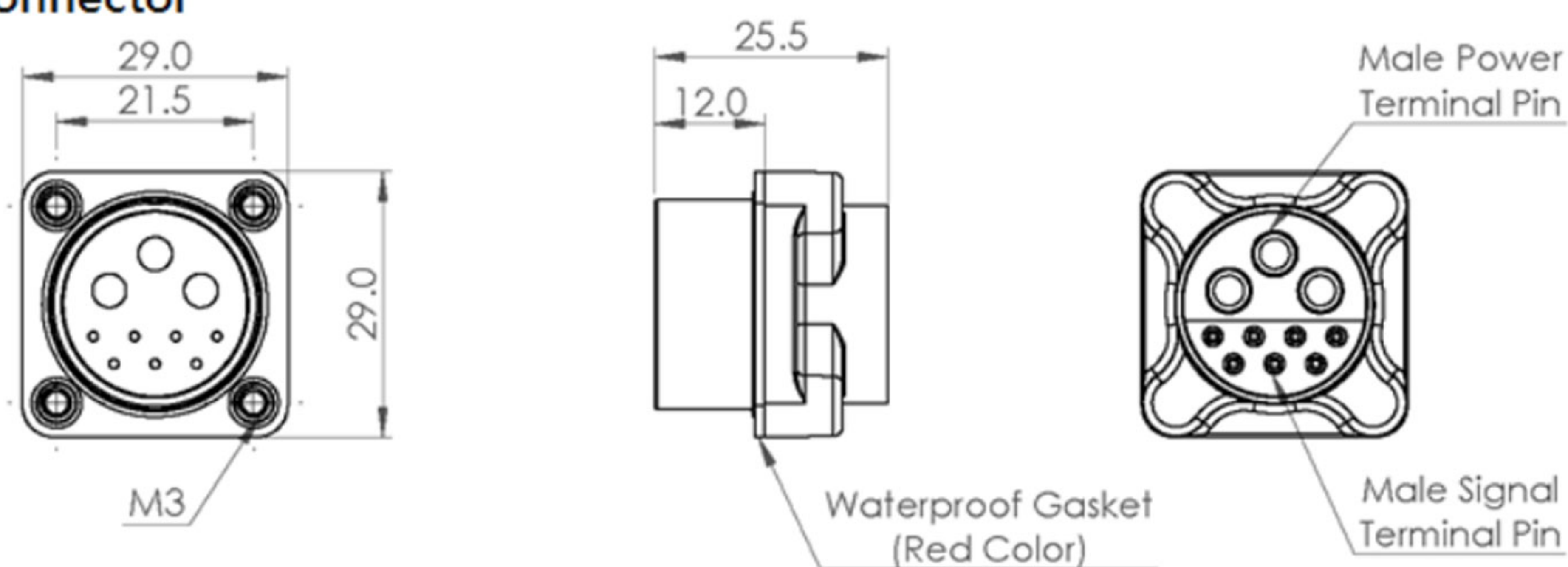

Features

Terminal	3 PWR. pin & 7 SIG. pin
	PWR. Terminal 30A
Current withstand	(Instantaneous peak current 40A)
	SIG. Terminal 2A
IP rating	IP68
Material of housing	PA66+15%GF UL94V0

Wire Information

Wire Spec. for Standard Sample	
Wire Gauge	
Power Terminal	14AWG to 10AWG
Signal Terminal	26AWG to 24AWG