

A7 Waterproof connector



Male Connector

Applications:

- E-Bike
- E-Scooter
- Drone
- Vacuum Cleaner
- Energy storage battery
- electric lawn mower
- AGV

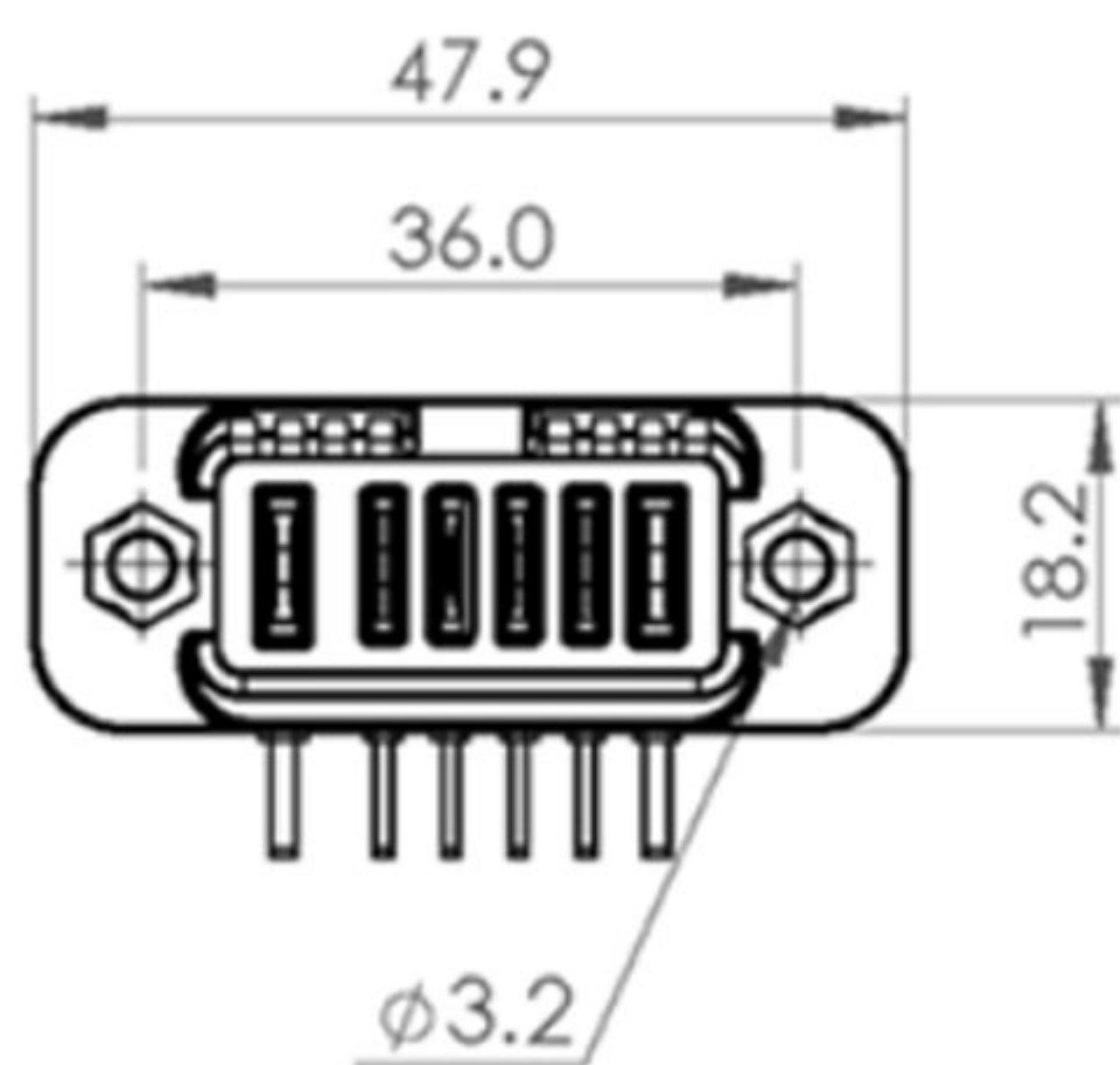

Female Connector

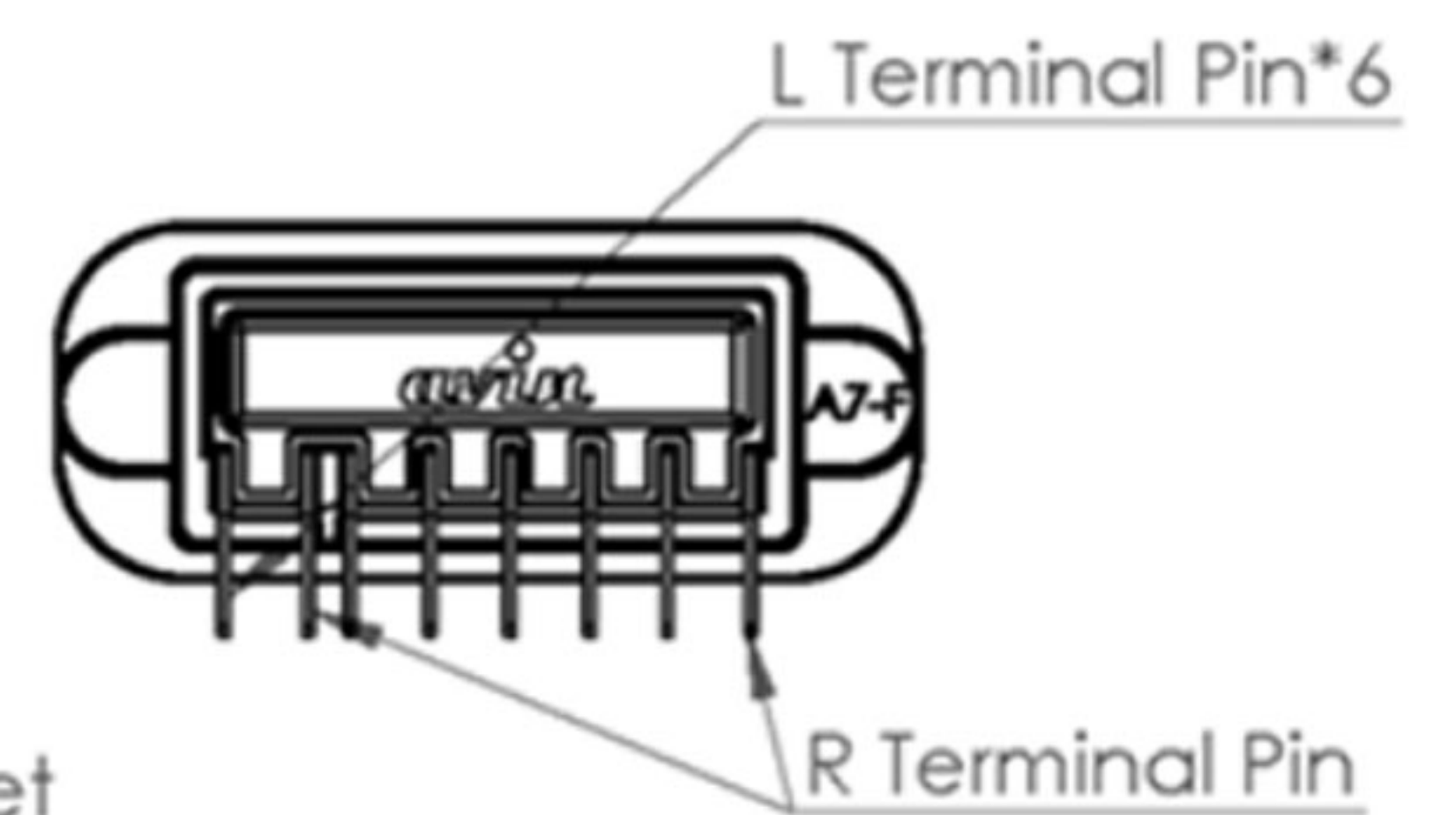
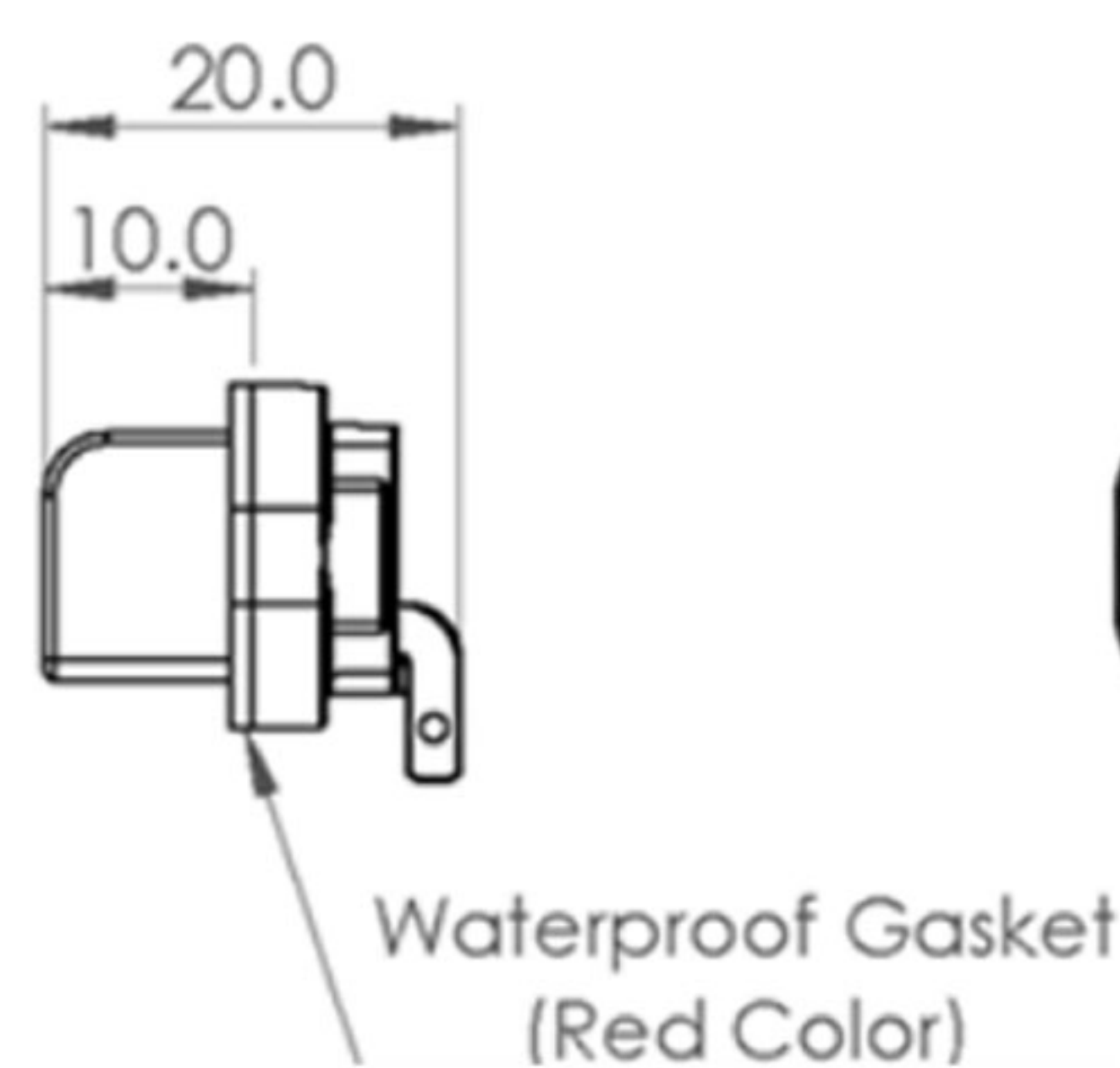
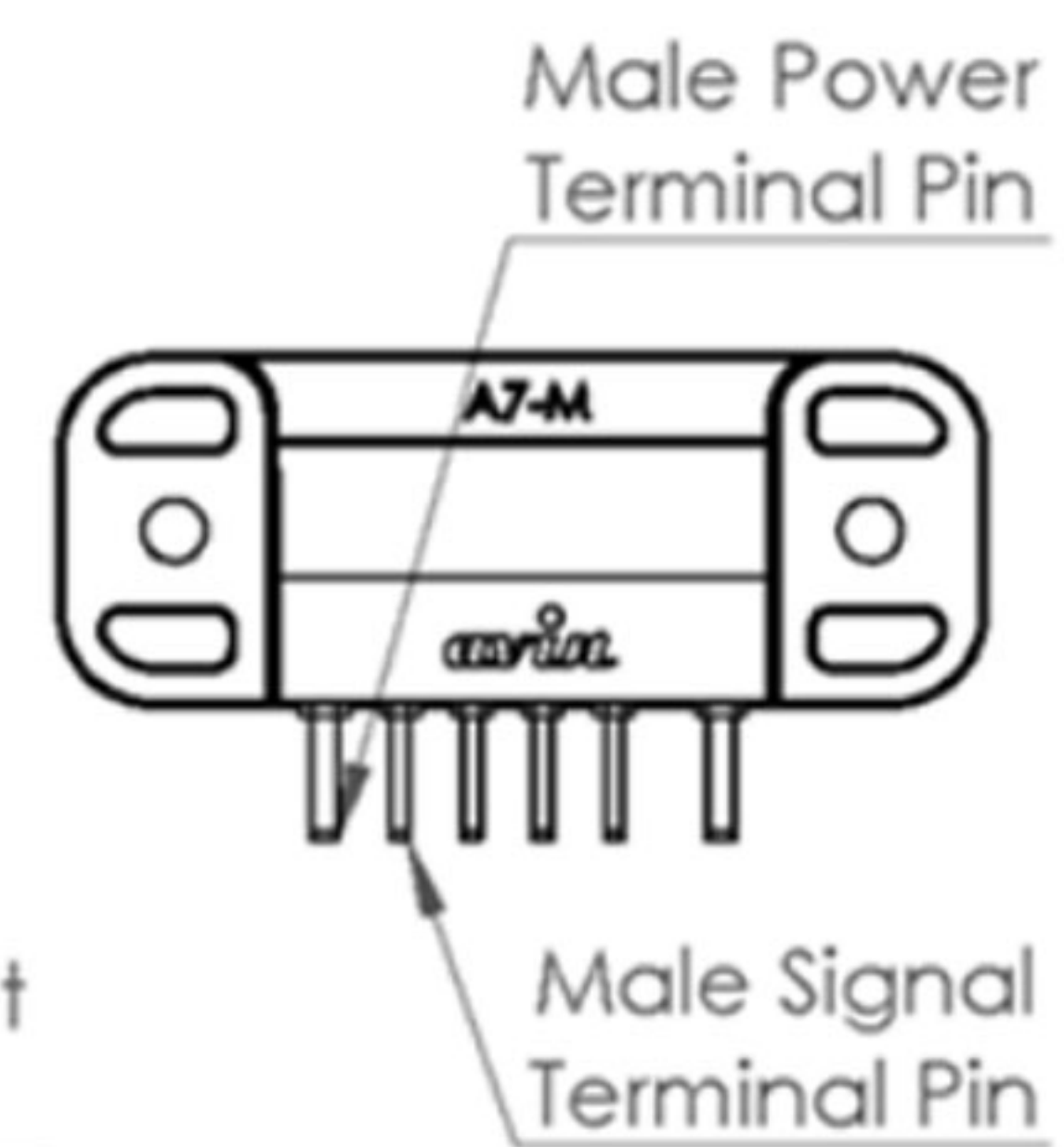
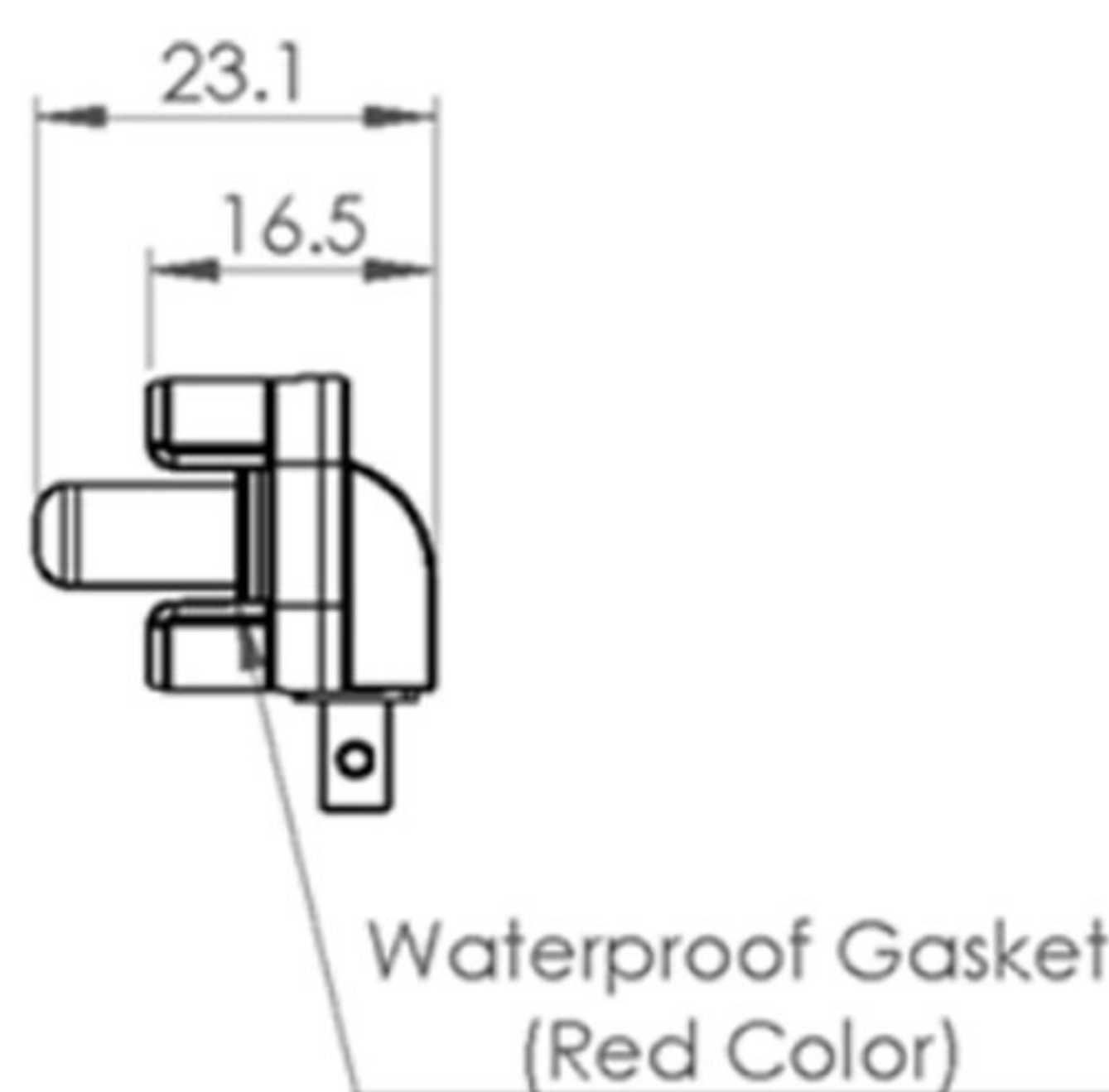
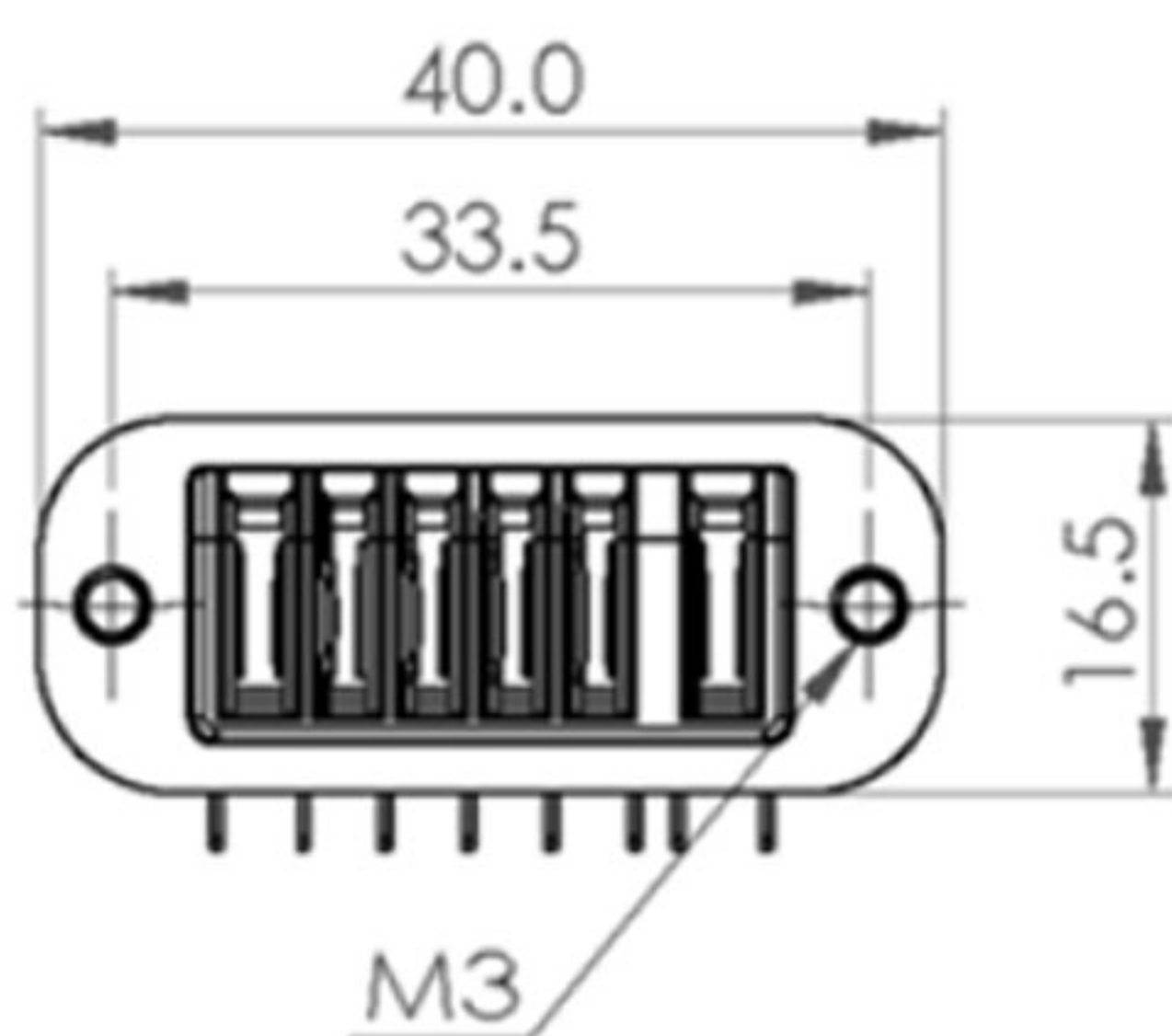

Features

Terminal	2 PWR. pin & 4 SIG. pin
	PWR. Terminal 30A
Current withstand	(Instantaneous peak current 40A)
	SIG.Terminal10A
IP rating	IP66
Material of housing	PA66+15%GF UL94 V0

Wire Information

Wire Spec. for Standard Sample	
Wire Gauge	
Power Terminal	10AWG
Signal Terminal	24AWG to 22AWG