

A1 Waterproof connector

Applications:

- E-Bike
- E-Scooter
- Drone
- Vacuum Cleaner
- Energy storage battery
- electric lawn mower
- AGV



Male Connector

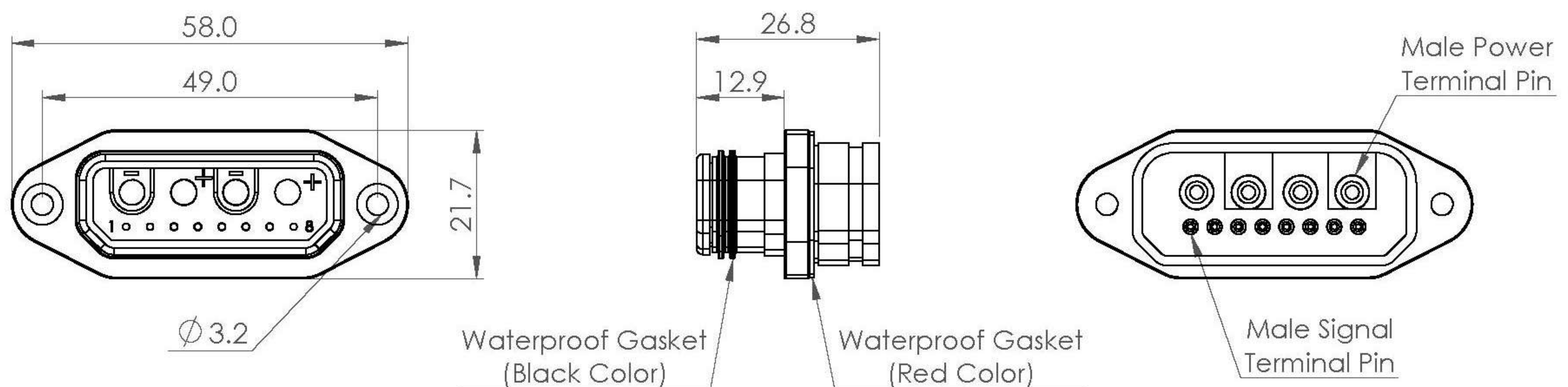

Female Connector

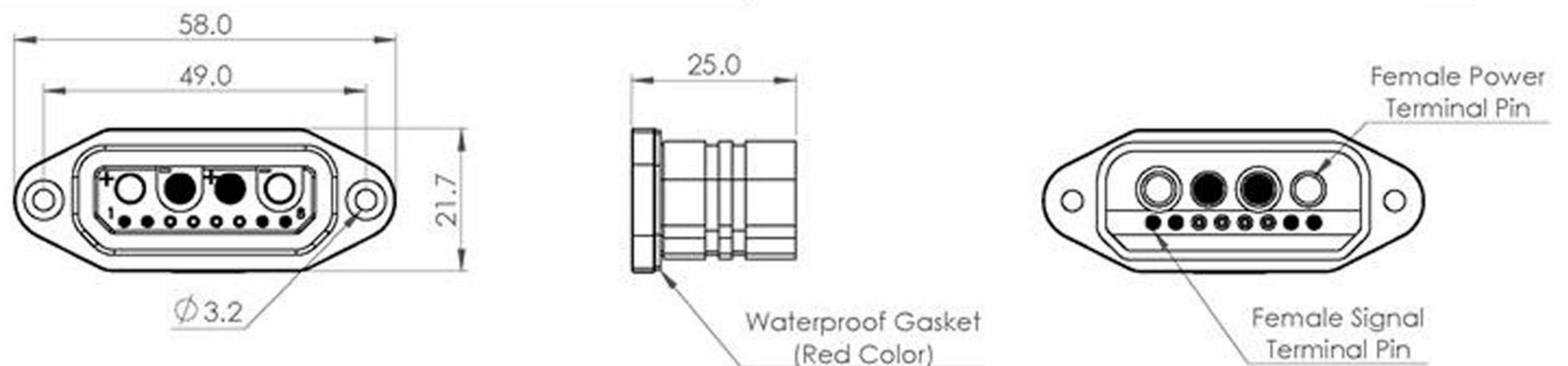

Features

Terminal	2P4S (MAX:4P8S)
	PWR.Terminal 30A
Current withstand	(Instantaneous peak current 40A)
	Signal terminal 2A
IP rating	IP68
Material of housing	PBT+GF15% UL94 V0

Wire Information

Wire Spec. for Standard Sample	
Wire Gauge	
Power Terminal	16AWG to 14AWG 12AWG to 10AWG
Signal Terminal	26AWG to 24AWG